



**Precision
Mixers**

Precision 140-Quart Mixer

Model M140-W

Standard Equipment and Features

- » 6 - Horse Power Drive Motor 208/240 Volt
- » 1/2 HP Lift Motor with gear reduction
- » 3-Phase Power
- » Gear-Reduction Transmission
- » 30-Minute Timer with automatic shut-off
- » 4-Speed
- » Stainless Steel Bowl Guard
- » Bowl Lift Safety
- » Electric Bowl Lift
- » Dough Hook
- » Wire Whip
- » Beater/Paddle
- » Stainless Steel Bowl
- » 4 Bowl Locking Handles
- » Bowl Stabilizer
- » Bowl Dolly, for easy transportation of mixed product
- » **Industry Leading, 3-Year Limited Parts Warranty**
- » **1-Year Full Parts and Labor Warranty**



Optional Accessories

- » 80-quart Knockdown Plate
- » 80-quart Bowl
- » Whip, Beater, and Hook for 80-quart Bowl
- » Pastry Knife
- » Heavy Duty Whip
- » Bowl Scraper

Please specify when ordering mixer.

**Built to Last . . .
Priced to Save!**

Precision North America, Inc.
60 Commerce Ave.
Albany, New York 12206



www.precisionmixers.com • Phone: 1-877-R-MIXERS (1-877-764-9377) • Fax: 518-462-3389



Specifications and Dimensions

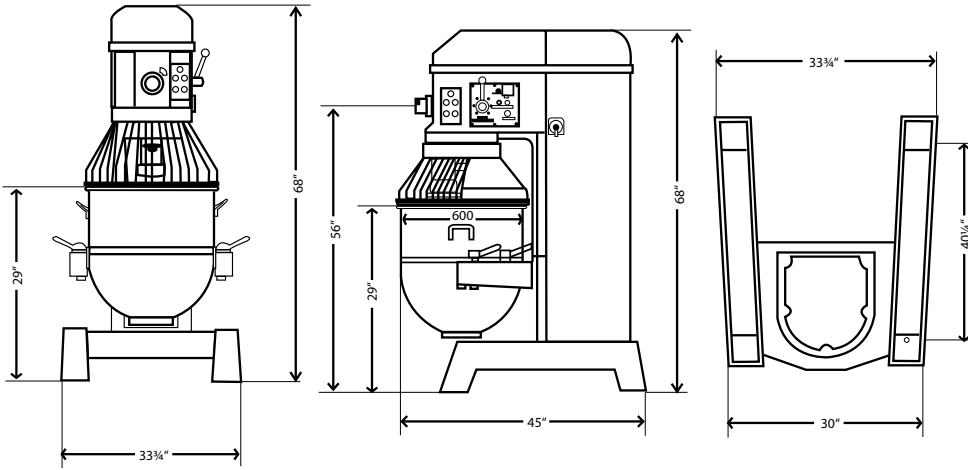

Electrical:

- 208/240 Volt
- 3-Phase Power
- Entela Approved

Weight:

- 2204 Pounds Net
- 2645 Domestic Shipping

Warranty:

- 3-Year Limited Parts, (Motor, Transmission, and Drive-Train)
- 1-Full Year Parts and Labor

Amp Draw Specifications

Phase	Volts	Amps
3	240	16.3

Dimensions

Mixer Body:

A: 33³/₄" Wide

B: 68" High

C: 45¹/₂" Depth

Bowl:

Outside w/handles: 28"

Inside: 23"

Height: 24"

NOTE: Hub attachment not to be used while mixing

Benefits

Motor:

- Heavy Duty, 6-Horse Power
- 1/2 HP lift Motor independent from Drive Motor
- Manual Reset Motor Overload

Bowl Lift:

- Locks in any position

Bowl Stabilizer:

- Flat Exterior Bowl Base for Bowl Stability

Timer:

- Automatic shutoff at desired mixing time

**Easy Maintenance and Service
National Network of Service
Professionals**

Safety features

Bowl Guard:

- Auto shut-off when bowl guard is opened.

Lift Safety:

- Auto shut-off when bowl is lowered.

Speed	Agitator RPMs
1	55
2	92
3	163
4	288

Specifications are subject to change.

Precision North America, Inc.
60 Commerce Ave.
Albany, New York 12206



www.precisionmixers.com • Phone: 1-877-R-MIXERS (1-877-764-9377) • Fax: 518-462-3389