



Standard Equipment and Features

- » 1 Horse Power Motor
- » 115 Volt
- » 12.67 Amps draw
- » Single Phase
- » 115/60/1
- » Gear-Driven Transmission
- » 30-Minute Timer with automatic shut-off
- » 3-Speed
- » #12 Attachment Hub
- » Safety Bowl Guard
- » Bowl Lift Safety
- » Dough Hook
- » Wire Whip
- » Beater/Paddle
- » Stainless Steel Bowl
- » Bowl Locking Handles
- » Bowl Stabilizer
- » **Industry Leading 3-Year-Limited Parts Warranty**
- » **1-Year Full Parts and Labor Warranty**



Built to Last . . . Priced to Save!

Precision North America, Inc.
60 Commerce Ave.
Albany, New York 12206



www.precisionmixers.com • Phone: 1-877-R-MIXERS (1-877-764-9377) • Fax: 518-462-3389



Specifications and Dimensions

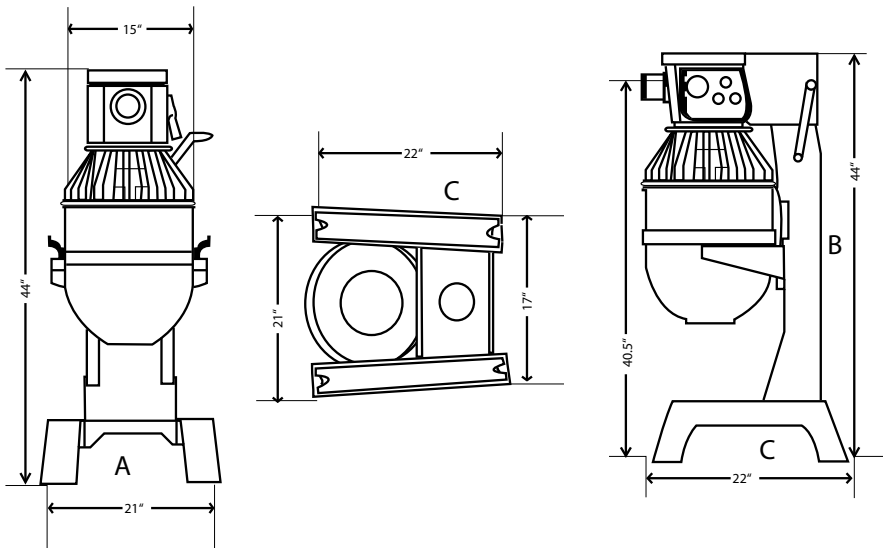

Electrical:

- 115 Volt
- 1-Phase Power
- Entela Approved
- 220V, 1 or 3 phase available

Weight:

- 352 Pounds Net
- 427 Domestic shipping

Warranty:

- 3-Year Limited Parts, (Motor, Transmission, and Drive-Train).
- 1-Full Year Parts and Labor.

Amp Draw Specifications

Phase	Volts	Amps
1	115	12.67

Dimensions

Mixer Body:

- A: 21" Wide
- B: 44" High
- C: 22" Length

Bowl:

- Outside w/handles: 18½"
- Inside: 14½"
- Height: 15½"

Benefits

Motor:

- Heavy-Duty, 1 Horse Power Motor
- Manual Reset Motor Overload

Bowl Stabilizer:

- Flat Exterior Bowl Base for Bowl Stability

Attachment Hub:

- Uses standard # 12 attachments

Power Supply:

- 6" Length Power Cord

Timer:

- Automatic shutoff at desired mixing time

Easy Maintenance and Service National Network of Service Professionals

Safety features

Bowl Guard:

- Auto shut-off when bowl guard is opened.

Lift Safety:

- Auto shut-off when bowl is lowered.

Speed	Agitator RPMs	Attachment Hub RPM's
1	78	136
2	140	245
3	250	437

NOTE: Hub attachment not to be used while mixing

Specifications are subject to change.

Precision North America, Inc.
60 Commerce Ave.
Albany, New York 12206



www.precisionmixers.com • Phone: 1-877-R-MIXERS (1-877-764-9377) • Fax: 518-462-3389