



**Precision
Mixers**

Precision 60-Quart Mixer

Model HD-60

Designed Exclusively for Pizzerias

Standard Equipment and Features

- » 208/240 Volt
- » Single or 3-Phase
- » Gear-Reduction Transmission
- » 30-Minute Timer with automatic shut-off
- » 3-Speed
- » #12 Attachment Hub
- » Stainless Steel Bowl Guard
- » Bowl Lift Safety
- » Manual Bowl Lift
- » Dough Hook
- » Beater/Paddle
- » Stainless Steel Bowl
- » Bowl Locking Handles
- » Bowl Stabilizer
- » **Industry Leading 7-Year Unconditional Warranty on All Gears and Shafts in the Planetary and Transmission**
- » **Also, Our Standard 1-Year / 3-Year Warranty**



Optional Accessories

- » 40-quart Knockdown Plate
- » 40-quart Bowl
- » 40-quart Paddle, Hook, and whip
- » Electric Bowl Lift
- » 80-quart bowl available for dough with very low A/R and cold water at no extra charge.

Please specify when ordering mixer.

**The Perfect Pizza Machine
at the perfect price!**

www.pizzamixers.com

Precision North America, Inc.
60 Commerce Ave.
Albany, New York 12206



www.precisionmixers.com • Phone: 1-877-R-MIXERS (1-877-764-9377) • Fax: 518-462-3389



Specifications and Dimensions

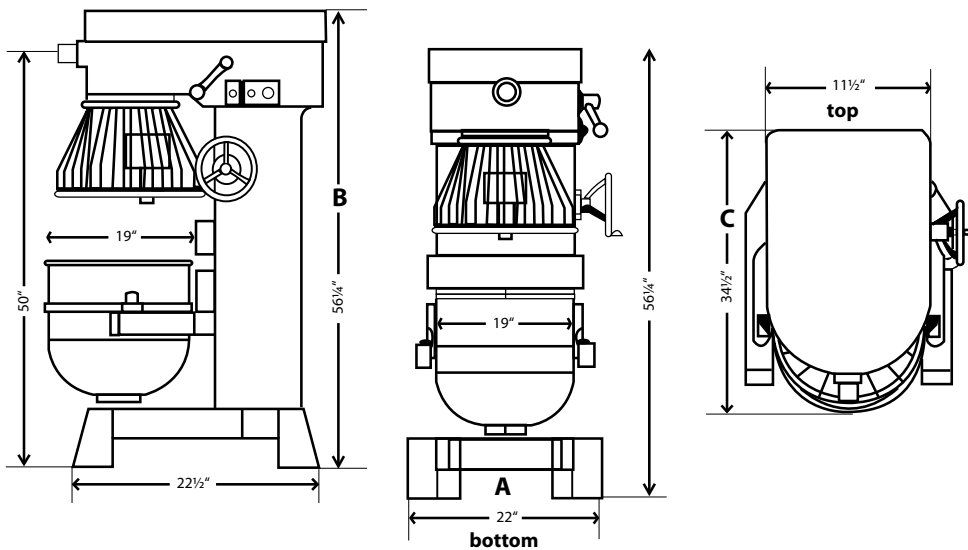

Electrical:

- 208/240 Volt
- 1 or 3-Phase Power
- Entela Approved

Weight:

- 875 Pounds Net
- 995 Domestic Shipping

Warranty:

- 3-Year Limited Parts, (Motor, Transmission, and Drive-Train)
- 1-Full Year Parts and Labor on entire machine.

Amp Draw Specifications

Phase	Volts	Amps
1	208	17
1	240	15
3	208	16.1
3	240	14

Dimensions

Mixer Body:

- A: 30" Wide
- B: 59 1/2" Wide
- C: 37" Wide

Bowl:

- Outside w/handles: 26" Wide
- Inside: 18 1/4" Wide
- Height: 18 1/2" Wide

NOTE: Hub attachment not to be used while mixing

Precision North America, Inc.
 60 Commerce Ave.
 Albany, New York 12206

Benefits

Motor:

- 4-Horse Power, 3-Phase
- 2-Horse Power, Single Phase
- Manual Reset Motor Overload

Bowl Lift:

- Locks in any position

Bowl Stabilizer:

- Flat Exterior Bowl Base for Bowl Stability

Attachment Hub:

- Uses standard # 12 attachments

Timer:

- Automatic shutoff at desired mixing time

**Easy Maintenance and Service
 National Network of Service
 Professionals**

Safety features

Bowl Guard:

- Auto shut-off when bowl guard is opened.

Lift Safety:

- Auto shut-off when bowl is lowered.

Speed	Agitator RPMs	Attachment Hub RPM's
1	65	74
2	124	142
3	208	239

Specifications are subject to change.

